

Clarke®

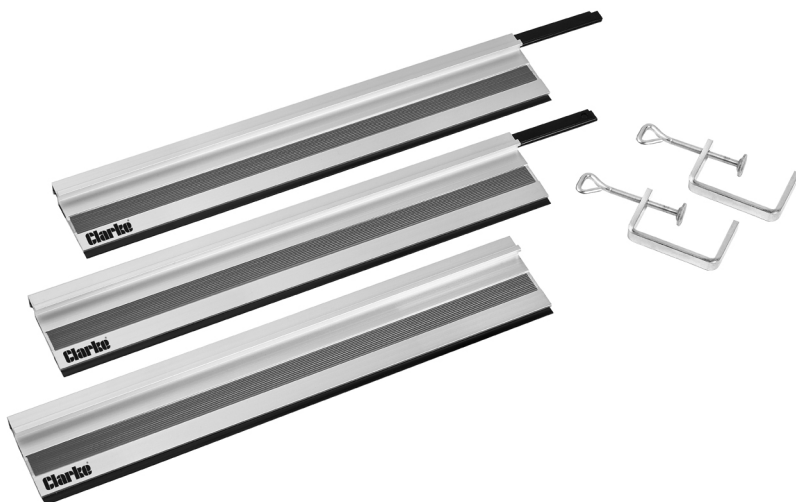

GUIDE RAIL SET FOR CPS85 PLUNGE SAW

MODEL NO: CPS85R

PART NO: 6460235

OPERATION & MAINTENANCE INSTRUCTIONS



ORIGINAL INSTRUCTIONS

LS0619 - ISS 1

INTRODUCTION

Thank you for purchasing this CLARKE Guide Rail set for CPS85 plunge saw.

Read this manual fully before you use this product and follow the instructions carefully. In doing so you will ensure the safety of yourself and that of others around you, and you can look forward to your purchase giving you long and satisfactory service.

GUARANTEE

This product is guaranteed against faulty manufacture for a period of 12 months from the date of purchase. Please keep your receipt which will be required as proof of purchase.

This guarantee is invalid if the product is found to have been abused or tampered with in any way, or not used for the purpose for which it was intended.

Faulty goods should be returned to their place of purchase, no product can be returned to us without prior permission. This guarantee does not effect your statutory rights.

CARTON CONTENTS

The following items should be supplied in the carton. If any parts are missing or damaged, please contact the Clarke dealer where you purchased the tool.

1 x Guide Rail Assembly (3 pieces and 2 joining bars)

2 x G Clamps

SPECIFICATIONS

Model Number	CPS85R
Overall Length	1260 mm

JOINING THE GUIDE RAILS TOGETHER

1. Place the two halves of the joining bar together as shown.

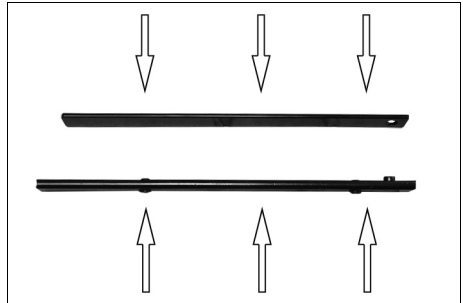

2. Slide the joining bar into the guide rail as shown and tighten the set screw.

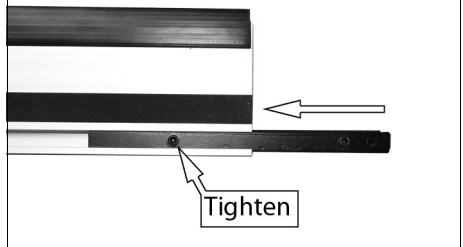

3. Slide the second guide rail over the joining bar and tighten the second set screw to lock in place.
4. Repeat steps 1-3 for the third guide rail

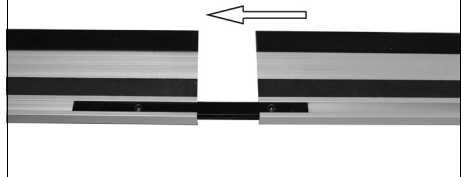

USING THE RAILS

Before using for the first time, perform a full length cut on a scrap piece of wood to cut the rubber lip on the rails flush to the blade.

NOTE: The saw will cut off a slither of the rubber leaving a perfect cut line.

1. Slide the rails up to the cut line.
 - The body of the rails should be placed on the part of the material you want the keep.

2. Clamp the rails in place using the supplied clamps as shown.

3. Place the plunge saw onto the guide rails.
4. Start the saw and push the saw down until you reach the set cutting depth.
 - Remember to add the thickness of the rails to your measured cutting depth.

5. Push the saw forwards to make the cut.

6. Release the on/off trigger and allow the saw to spring up when the saw cutting is complete.

